

(DE) Ersatzteile
(FR) Pièces de rechange
(EN) Spare parts
(IT) Ricambi
(NL) Reserveonderdelen
(ES) Piezas de repuesto
(SV) Reservdelar
(DA) Reservedele
(FI) Varaosat
(PL) Części zapasowe
(RU) Запчасти

Pos. Nr. / Pt n° / Item No. / Pos. n. / N.º pos. / Pos. nr / Pos.nr. / Paikkanro / Nr poz. / №	Art. Nr. / Réf. / Ref. No. / N. art. / N.º de art. / Art-nr. / Varenr. / Tuo- tenno / Nr art. / Арт. №	Menge / Quantité / Quantity / Quantità / Hoeveelheid / Cantidad / Mängd / Mængde / Määrä / Liczba sztuk / Количество
1	18810-0	1
2	18810-2	1
3	18811	1
4	18810-16	1
5	18816	1
6	18810-14	1
7	18821	1
8	18822	1
9	6438	6
10	18810-20	2
11	6400	18
12	6413	14
13	6690	8
14	6414	8
15	-	1
16	18812-3	1
17	18810-21	1
18	6409	2
19	6402	8
20	6403	7
21	18810-22	1
22	18810-10	1
23	6401	8
24	-	1
25	18810	1
26	18811-2	1
27	18811-1	1
28	18810-15	1
29	18810-5	1
30	6419 (t=0,3)	1
30	6420 (t=1,0)	2
30	6421 (t=2,0)	2
31	6411	1
32	6417	2
33	18810-13	1
34	18810-12	1
35	6408	4
36	6415	8
37	-	1

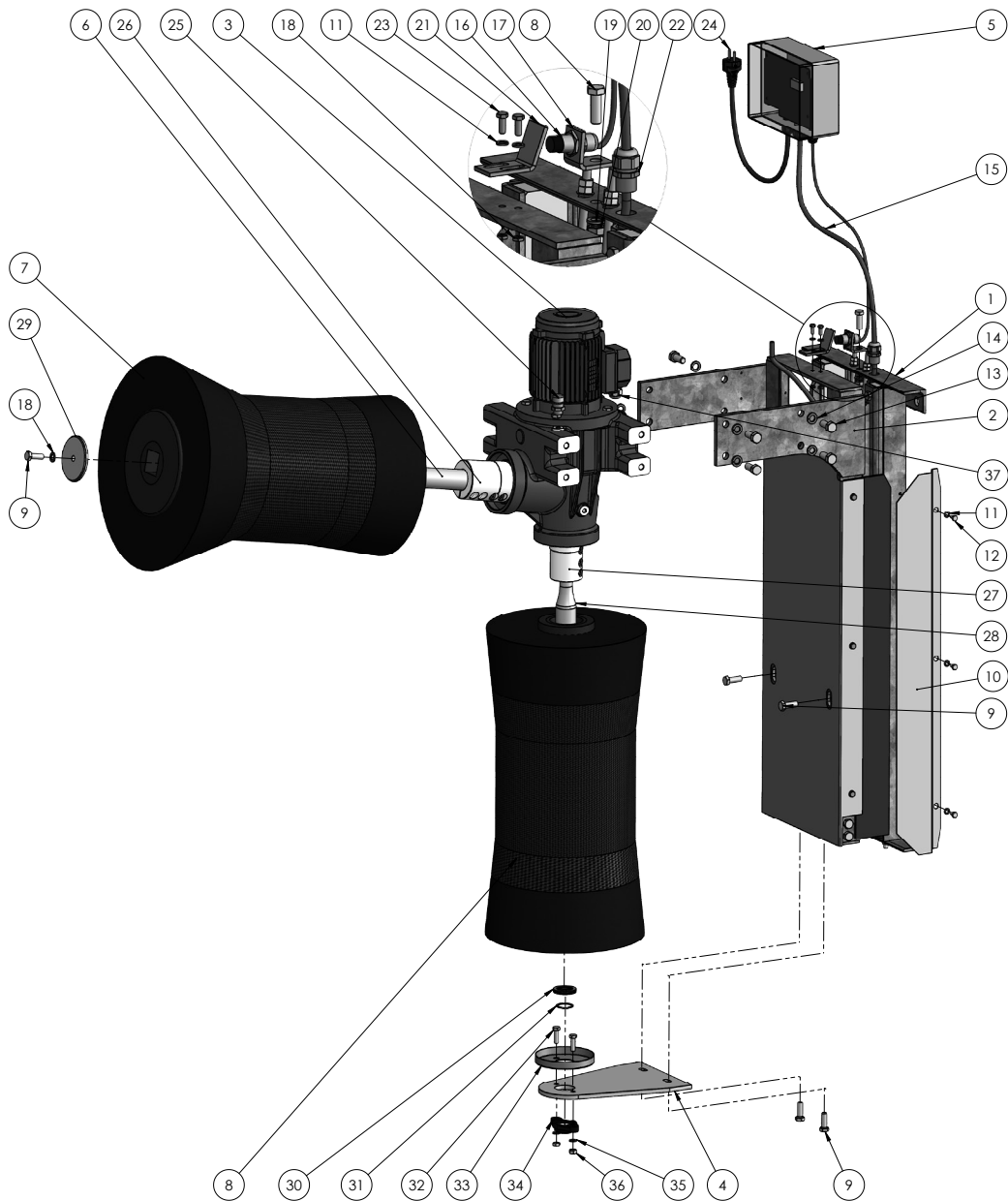

(DE) Abbildung 12
 (FR) Figure 12
 (EN) Figure 12
 (IT) Figura 12
 (NL) Afbeelding 12
 (ES) Figura 12
 (SV) Bild 12
 (DA) Ill. 12
 (FI) Kuva 12
 (PL) Rysunek 12
 (RU) Рисунок 12

Pos. Nr. / Pt n° / Item No. / Pos. n. / N.º pos. / Pos. nr / Pos.nr. / Paikkanro / Nr poz. / №	Art. Nr. / Réf. / Ref. No. / N. art. / N.º de art. / Art-nr. / Varenr. / Tuotenumro / Nr art. / Арт. №	Menge / Quantité / Quantity / Quantità / Hoeveelheid / Cantidad / Cantidat / Mængde / Määrä / Liczba sztuk / Количество
1.1	18810-0	1
1.2	18810-1	2
1.3	6460	4
1.4	18753-1	2
1.5	18753	2
1.6	6416	2
1.7	6415	6
1.8	18810-25	2
1.9	6408	2

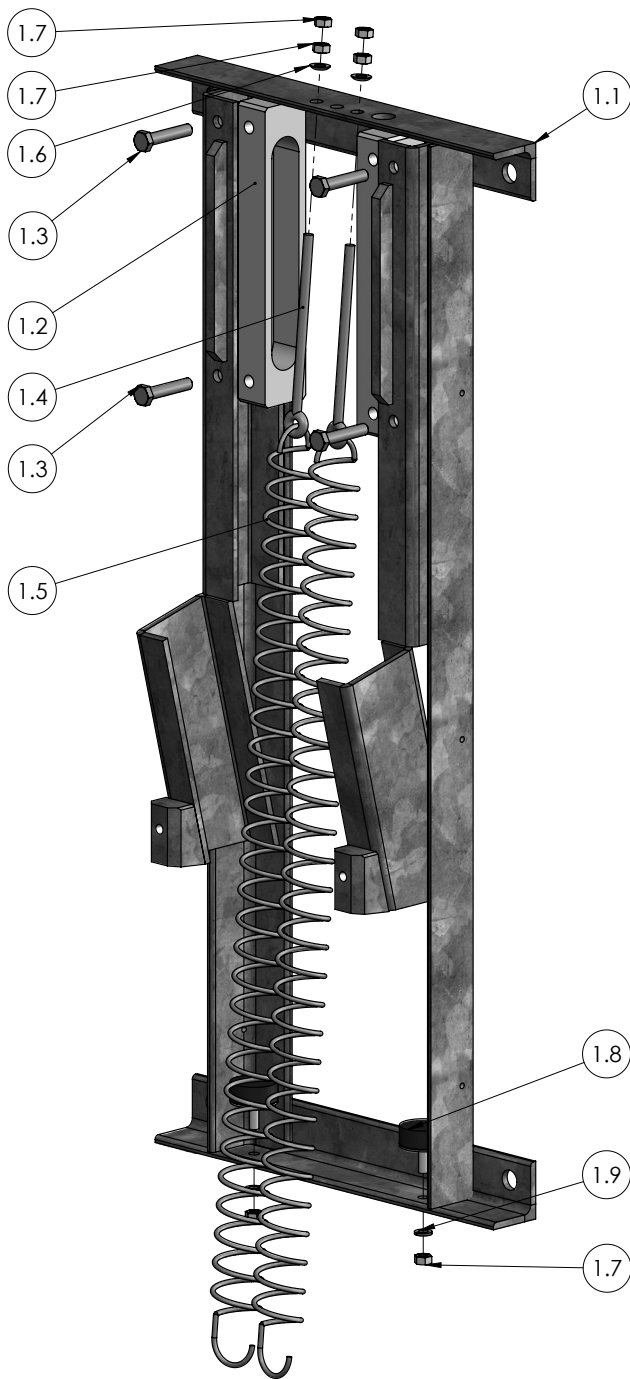

(DE) Abbildung 13
(FR) Figure 13
(EN) Figure 13
(IT) Figura 13
(NL) Afbeelding 13
(ES) Figura 13
(SV) Bild 13
(DA) Ill. 13
(FI) Kuva 13
(PL) Rysunek 13
(RU) Рисунок 13

Pos. Nr. / Pt n° / Item No. / Pos. n. / N.º pos. / Pos. nr / Pos.nr. / Paikkanro / Nr poz. / №	Art. Nr. / Réf. / Ref. No. / N. art. / N.º de art. / Art-nr. / Varenr. / Tuotenro / Nr art. / Арт. №	Menge / Quantité / Quantity / Quantità / Hoeveelheid / Cantidad / Quantità / Mængd / Mængde / Määrä / Liczba sztuk / Количество
2.1	18810-2	1
2.2	18810-4	1
2.3	18810-9	2
2.4	6400	10
2.5	6401	6
2.6	6413	8
2.7	6405	8
2.8	18810-27	2
2.9	6410	2
2.10	18810-6	2
2.11	18810-26	2
2.12	18810-19	4
2.13	18810-18	2
2.14	6402	4
2.15	6403	4
2.16	6412	4
2.17	18810-8	2
2.18	18810-23	2
2.19	6423	4

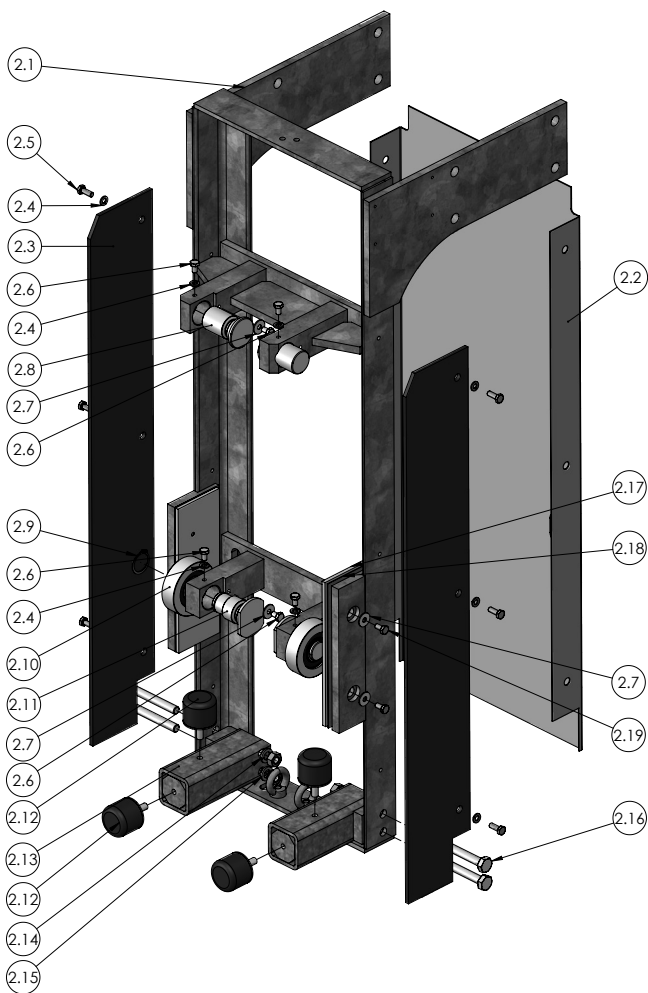

(DE) Abbildung 14
(FR) Figure 14
(EN) Figure 14
(IT) Figura 14
(NL) Afbeelding 14
(ES) Figura 14
(SV) Bild 14
(DA) Ill. 14
(FI) Kuva 14
(PL) Rysunek 14
(RU) Рисунок 14

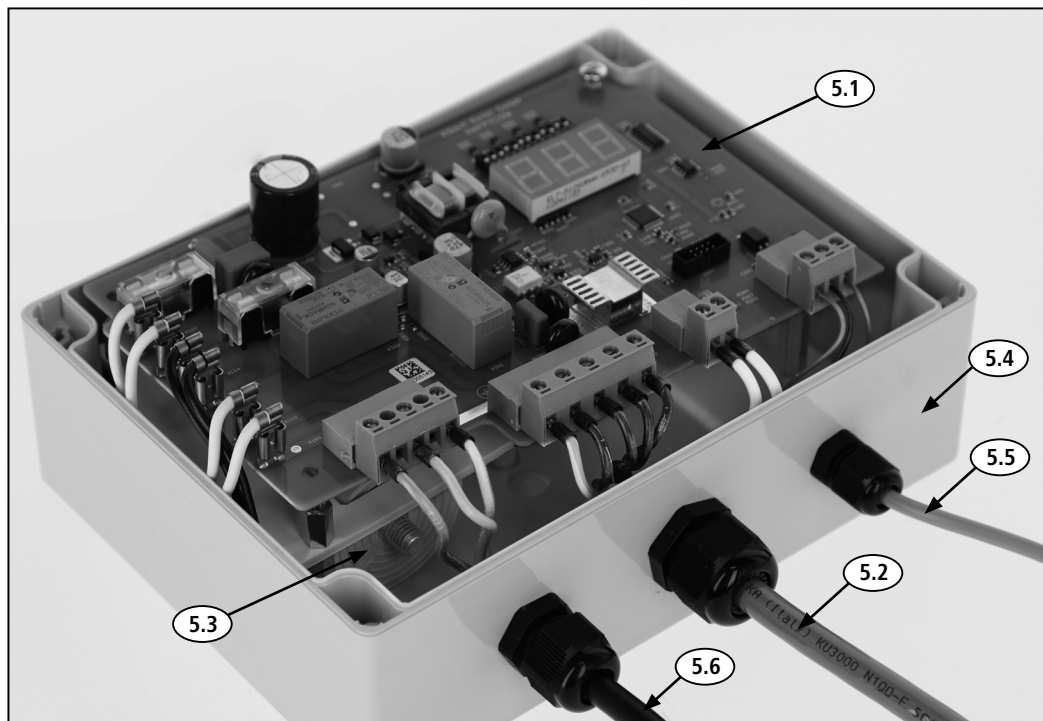

Pos. Nr. / Pt n° / Item No. / Pos. n. / N.° pos. / Pos. nr / Pos.nr. / Paikkanro / Nr poz. / №	Art. Nr. / Réf. / Ref. No. / N. art. / N°. de art. / Art-nr. / Varenr. / Tuotenro / Nr art. / Арт. №	Menge / Quantité / Quantity / Quantità / Hoeveelheid / Cantidad / Mängd / Mængde / Määrä / Liczba sztuk / Количество
5	18816	1
5.1	18816-1	1
5.2	18816-2	1
5.3	18816-3	1
5.4	18816-4	1
5.5	18812-3	1
5.6	-	1

(DE) Abbildung 15 – Steuerung, Explosionsansicht
 (FR) Figure 15 – Unité de contrôle, vue en éclaté
 (EN) Figure 15 - Control unit, exploded view
 (IT) Figura 15 – Unità di controllo, vista esplosa
 (NL) Afbeelding 15 – besturing, explosietekening
 (ES) Figura 15: Unidad de control (perspectiva explosionada)
 (SV) Bild 15 – styrsystem, explosionsvy
 (DA) Ill. 15 – Styring, eksplosionstegning
 (FI) Kuva 15 – Ohjausyksikkö, räjäytyskuva
 (PL) Rysunek 15 – Sterownik, widok po rozłożeniu
 (RU) Рисунок 15. Блок управления, перспективное объемное изображение с пространственным разделением деталей